

Operation Instruction

Solar Hot Water Pump Station



 Please read this instruction carefully!

eautek

Contents

1. Solar pump station with integrated controller.....	2
1.1 Scope of delivery	2
1.2 About this manual	3
1.3 Safety instructions	3
1.4 Station dimensions:	4
1.5 Specification of components.....	4
2. Mounting station	6
3. Commissioning of station	7
3.1 Flushing and filling the solar system	7
3.2 Flow check.....	8
3.3 Manual / Automatic integrative air bleeder	8
3.4 Electrical connection and operation instruction of controller (see manual of controller) ...	9

1. Solar pump station with integrated controller

- Integrated controller
- Outstanding design
- Safe assembly with safety valve
- High-Quality casing for reduction of heat loses
- Easy Flow rate monitoring

1.1 Scope of delivery

- 1* solar pump station
- 1* integrated solar controller
- 1* wall mounting bracket
- 1* accessory bag
- 1* manual



Note:

1) Integrated solar controller description:

Solar pump station for dual pipelines with conventional pump.

Controller Model



Add EAUTEK Logo in this place

1.2 About this manual

This manual includes information on operation and maintenance of solar pump station used to circulate heat transfer fluid from the collectors to the storage tank, which passes through necessary safety devices in the station preinstalled and tested in the factory.

- Ball valves in flow and return in combination with check valves to prevent gravity circulation.
- Air stopper for manual bleeding of the solar thermal system.
- Electronic flow rate monitoring.
- Pressure gauge for displaying the system pressure.
- Safety valve to prevent inadmissible overpressure.
- Flushing and filling unit for flushing, filling and emptying the solar thermal system.

1.3 Safety instructions

The installation and commissioning of the solar station as well as the connection of electrical components requires technical knowledge commensurate with a recognized vocational qualification as a fitter for plumbing, heating and air conditioning technology, or a profession requiring a comparable level of knowledge. The following must be observed during installation and commissioning:

- The relevant regional and national regulations.
- The technical and safety instructions.



Warning: risk of scalding

There is danger of steam emission with safety valves. Therefore a discharge pipe must be connected to the safety assembly, please observe the enclosed instructions regarding the safety valve when doing this.



Attention: damage of solar pump station

- The group of fittings must be installed with sufficient spacing to the collectors because temperatures in the vicinity of the collectors can be very high. An intermediate vessel may be necessary for installation in the attic.
- It is imperative that you make sure the EPDM sealing elements of the solar pump station do not come into contact with substances containing mineral oil. Mineral oil products cause lasting damage to the material, whereby its sealant properties are lost. If necessary, ask the manufacturer whether the solar fluid, fats or installation aids contain

mineral oils.

We don't assume liability nor provide warranty for damage to solar station resulting from sealants damaged in this way.

1.4 Solar Pump Station Dimensions:

- Height (with insulation): 450mm
- Width (with insulation): 300mm
- Depth (with insulation): 158mm
- Distance centre: 1600mm
- Distance axis/wall: 55mm
- Pipe connections: 3/4" IT
- Connection for expansion vessel set: 3/4" ET, flat sealing
- Outlet safety valve: 1/2 IT

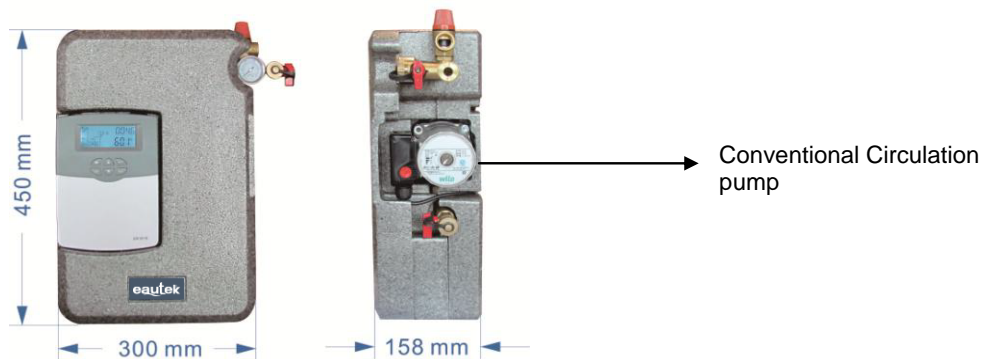

1.5 Specification of components

- 1) Non-return valve: opening pressure 200mmH₂O
- 2) Connector of flow outlet (to collector): 3/4" IT
- 3) Safety valve: 6bar
- 4) Filling connector
- 5) Connector of expansion vessel
- 6) Manometer: 0-6bar

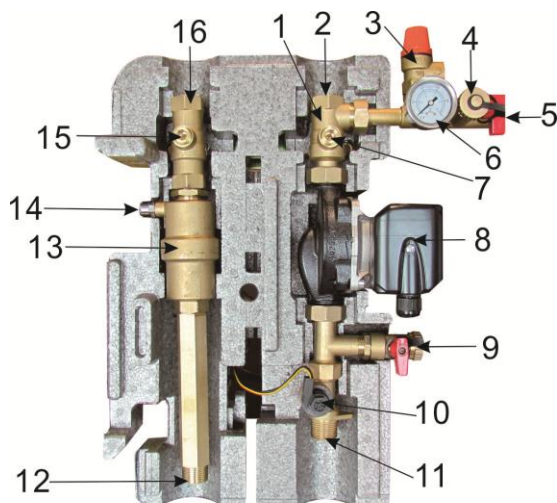

- 7) Sensor on return pipe (from tank to collector),NTC10K (optional)
- 8) Circuit pump:
Conventional pump : Winflo Circulation pump
- 9) Connection of drainage valve
- 10) Digital flow counter Return outlet connection (from collector): 3/4 IT
- 11) Connection to flow inlet (from tank):3/4' IT
- 12) Connection to flow outlet (to tank):3/4' IT
- 13) Air separator
- 14) Manual air bleeder
- 15) Sensor on flow pipe
- 16) Connection to flow inlet :3/4' IT

Material:

Fitting: Brass

Seals: PTFE

Insulation: EPP, $\lambda = 0.041\text{W}/(\text{m}\cdot\text{K})$

1.6 Technical Data

Max. permitted pressure: 6bar

Max. permitted operating temperature: 120°C

Digital flow rate FRT: 1-20L/Min

2. Mounting Pump Station

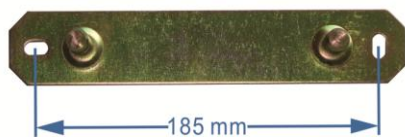

Distance between two screws 185mm

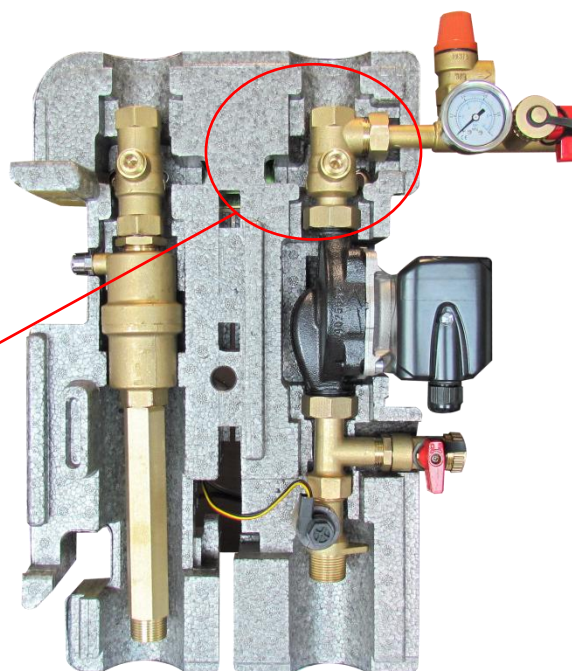
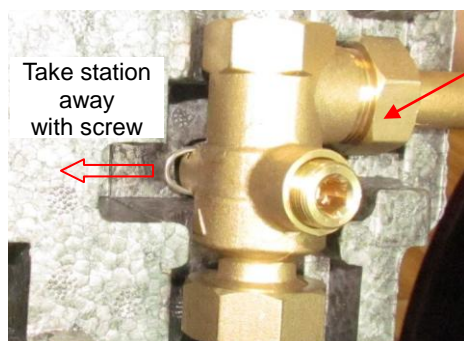

- Determine the mounting site of the station.
- Take the station out of packing; remove the upper insulation cover.
- Hold the enclosed wall mounting bracket against the wall and mark the fastening holes, drill holes and insert dowels.
- Fasten the wall mounting bracket to the wall with the screws.
- Push the station against the wall mounting bracket is then fixed to the wall.
- Connect the station to the solar thermal system.
- Check the inlet pressure of the expansion vessel and if necessary, adjust it to the local conditions, $P_{inlet}(\text{bar}) = 1\text{bar} + \Delta Th(\text{m}) * 1/10$ (ΔTh =height difference between collector and station) .
- Connect the electrical components of the solar station, connect sensor of storage and collector and connect them to the controller, plug the controller into the socket.
- Tighten all union nuts and screw connections.
- Attach the front half of the insulation to the station.

i **Note:** if you want to take down the solar station, just use screw with “-” head screw, see picture shows above.

3. Commissioning of station

i **Attention: Risk of scalding!**

In order to prevent the boiling of solar fluid in the collectors, the system should not be flushed or filled during periods of strong sunshine.

i **Attention: Risk of frost!**

Solar thermal system cannot be completely emptied after flushing. There is a danger of frost damage if water is used for flushing. Only use solar fluid to flush and fill the solar thermal system. Use water –propylene glycol mixture as solar fluid (Maximum 50% propylene glycol).

3.1 Flushing and filling the solar system

Flushing and filling connector is already integrated in the solar station, and we still recommend installing a filling and drainage valve horizontally at the lowest point of the solar circuit for flushing system.

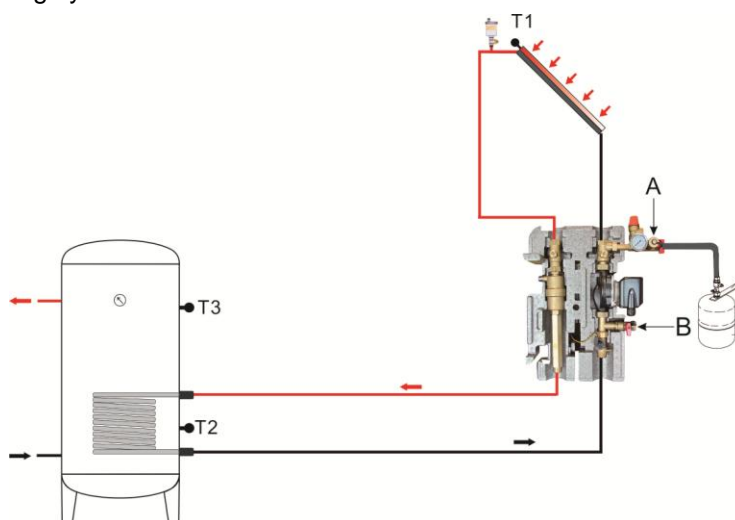

Flushing and filling steps:

- Disconnect the expansion vessel from the solar thermal system.
- Connect the pressure hose of a flushing and filling station to the fill ball valve (A) of pump station.
- Connect the flushing hose of a flushing and filling station to the drain ball valve (B) of pump station.
- Open the filling ball valve (A) and drain ball valve (B).
- Flush the solar thermal system using the flushing and filling station for at least

15minutes to remove all air from the system.

- During the flushing, bleed the solar thermal system several times at the air stopper until the discharged solar fluid is free of air bubbles.
- Close the drain ball valve (B) of flushing and filling unit, and continues run the pump and increase the system pressure to approx.5 bar, system pressure can be read from the manometer.
- Close the filling ball valve (A) of pump station, and then close the filling pump.
- Check the pressure gauge to see whether the system pressure reduces and eliminate leaks where necessary.
- Reconnect the expansion vessel to the solar thermal system.

3.2 Flow check

The flow counter is used for measurement and display of flow rate 1-20L/M, in order to guarantee the flawless function of the measuring device the system must be flushed and free from foreign substances.

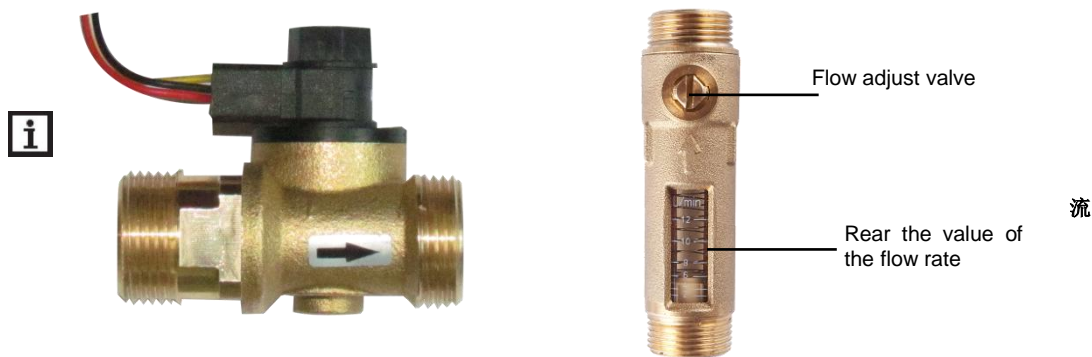

Digital flow counter FRT (1-20L/Min)

Mechanical flow meter (2-12L/min)

i Note: Factory delivery with digital flow meter. (Mechanical flow meter is optional part)

3.3 Manual / Automatic integrative air bleeder

After filling solar liquid and commissioning the system, air bleeder will release air automatically, but you can also release air manually.

- Air bleeder is positioned to the automatic status in factory.
- When air bleeder in automatic status

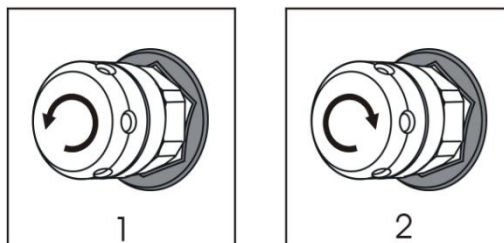

position, then turn head 180 anticlockwise, the air bleeder changed to manual status (see 1)

- When air bleeder in manual status position, then turn head 180 clockwise, the air bleeder changed to automatic status (see 2)
- Manual air bleeder is used to release the air of the system. Air released from solar liquid gathered at the upper part of air separator (see picture 3), and released from there, in order to release air easily, Speed of flow should be at least 0.3m/s.
- After air releasing, please check the system pressure, if necessary please increase the system pressure up to the required one.



 **Warning:** high temperature scald. When air releasing, air temperature or liquid temperature maybe over 100oC.

3.4 Electrical connection and operation instruction of controller (Refer Controller manual for details)

 **Warning:** disconnect the controller from power supply before opening the housing!

The controller is already integrated in the station and ready to plug in, display and digital counter are already preinstalled at factory. For maintenance or service work, controller must be uninstalled from station, follows the below steps:

- Switch off the system, disconnect plug from the mains.
- Remove the front half of the insulation.
- Unscrew the cross-recessed screw of the front cover of controller and remove it by pulling it downwards.
- Disconnect the wires from controller, take out the controller.
- Doing reverse steps to remount the controller.

 For further information on electrical connection of the controller, please see manual of controller (terminal layout).