

dot-X[®]

Operation Manual

Storage Electric Water Heater



**Please read the instruction manual carefully
before use, and keep it for future reference.**

EAU TECHNIK GmbH

Email: info@eautek.com, Website: www.eautek.com

Sincerely thank you for selecting our electric water heater. Please read this manual carefully before use; correctly grasp the methods for installation and use of this electric water heater, to make full use of its excellent performances.

Special advice

- Before installing this water heater, check and confirm the earth electrode on the socket is reliably grounded, without electricity. Otherwise, the electric water heater can not be installed and used.
- No use of mobile sockets.
- Incorrect installation and use of this electric water heater may result in serious injuries to human bodies and losses of property.

Contents

- Performance characteristics.....(1)
- Explanation of model.....(2)
- Specifications.....(2)
- Product appearance.....(2)
- Brief introduction of product structure.....(3)
- Methods of installation.....(3)
- Methods of use.....(5)
- Cautions.....(5)
- Maintenance.....(7)
- Failures and treatment.....(7)
- Wiring diagram.....(8)

Performance characteristics

1. Completely automatic control: automatic addition of cold water, automatic heating.
2. Four-fold safety protection: multiple safety protection devices, such as dry heating protection, extra-temperature protection, electric leakage protection, high hydraulic pressure protection, etc., safe and reliable.
3. Sapphire enamel inner container: manufactured by using advanced electrostatic dry method enamel technique, antirust, corrosion-proof, incrustation-resistant, leak-prevention, with longer lifetime.
4. Heating pipes designed with low thermal load: safe and reliable, with longer lifetime.
5. Equipped with corrosion-proof and incrustation-retardant equipment: durable products.
6. Thickened urethane integral foaming: good thermal insulation effect, energy efficient and electricity saving.
7. Imported temperature controller: accurate and reliable control of temperature.
8. Adjustable range of water temperature from 30 to 75°C.
9. Simple operation and easy use.

Specifications

| Model | Volume (L) | Rated power (W) | Rated voltage (ACV) | Rated pressure (MPa) | Max of water temperature (°C) | Electric type | Waterproof grade |
|-------------|------------|-----------------|---------------------|----------------------|-------------------------------|---------------|------------------|
| DT-50H-S01 | 50 | 1500 | 220 | 0.75 | 30~75 | Type I | IPX4 |
| DT-80H-S01 | 80 | 1500 | 220 | 0.75 | 30~75 | Type I | IPX4 |
| DT-100H-S01 | 100 | 1500 | 220 | 0.75 | 30~75 | Type I | IPX4 |

Product appearance

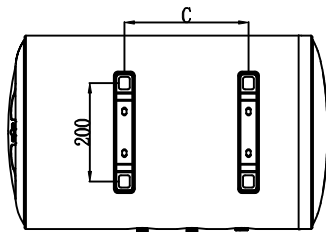
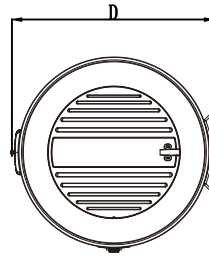
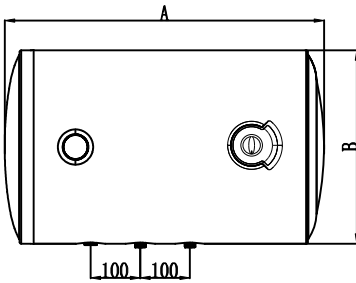

| capacity | A | B | C | D |
|----------|-----|-----|-----|-----|
| 50L | 655 | 390 | 250 | 410 |
| 80L | 780 | 440 | 300 | 475 |
| 100L | 930 | 440 | 450 | 475 |

Brief introduction of product structure

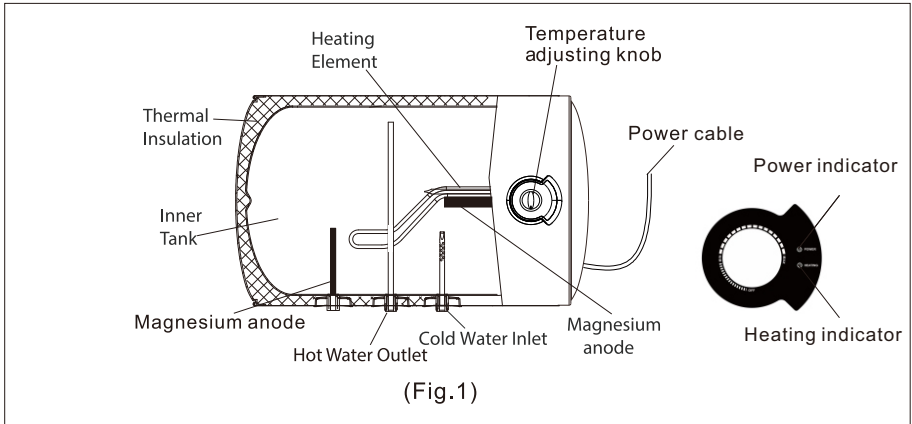

Methods of installation

Note: Please be sure to use the accessories provided by our company to install this electric water heater. This electric water heater can not be hung on the support until it has been confirmed to be firm and reliable. Otherwise, the electric water heater may drop off from the wall, resulting in damage of the heater, even serious accidents of injury. When determining the locations of the bolt holes, it shall be ensured that there is a clearance not less than 0.2m on the right side of the electric heater, to convenient the maintenance of the heater, if necessary.

1. Installation of the main machine

1. This electric water heater shall be installed in the solid wall. If the strength of the wall can not bear the load equal to two times of the total weight of the heater filled fully with water, it is necessary to install a special support.
2. After selecting a proper location, determine the positions of the two install holes used for expansion bolts with hook (determined according to the specification of the product you select). Make two holes in the wall with the corresponding depth by using a chopping bit with the size matching the expansion bolts attached with the machine, insert the screws, make the hook upwards, tighten the nuts to fix firmly, and then hang the electric water heater on it (see Fig.2).

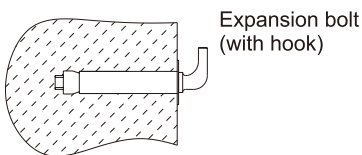

Horizontal installation

| | | | |
|----------------------------|-----|-----|-----|
| Volume(L) | 50 | 80 | 100 |
| Distance between holes(mm) | 250 | 300 | 450 |

(Fig.2)

3. Install the supply socket in the wall. The requirements for the socket are as follows: 250V/16A, single phase, three electrodes. It is recommended to place the socket on the right above the heater. The height of the socket to the ground shall not be less than 1.8m.
4. If the bathroom is too small, the heater can be installed at another place without sun-scorched and rain-drenched. However, in order to reduce the pipeline heat losses, the installation position of the heater shall be closed to the location for use of water as near as possible.

2. Connection of pipelines

1. The dimension of each pipe part is G1/2.
2. Connection of one-way safety valve: install the one-way safety valve attached with the machine at the water inlet of the main machine. (Pay attention to keep the installed drainage flexible pipes of the safety valve sloping downward and connected with the atmosphere.)
3. In order to avoid leakage when connecting the pipelines, the rubber seal gaskets provided with the machine must be added at the end of the threads (see Fig.3).

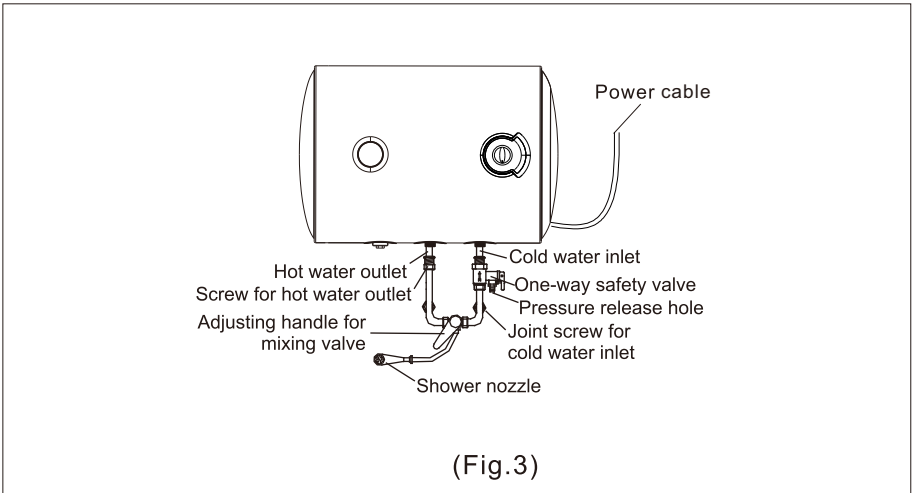

4. If the users want to realize a multi-way supply system, refer to the method shown in Fig.4 for connection of the pipelines.

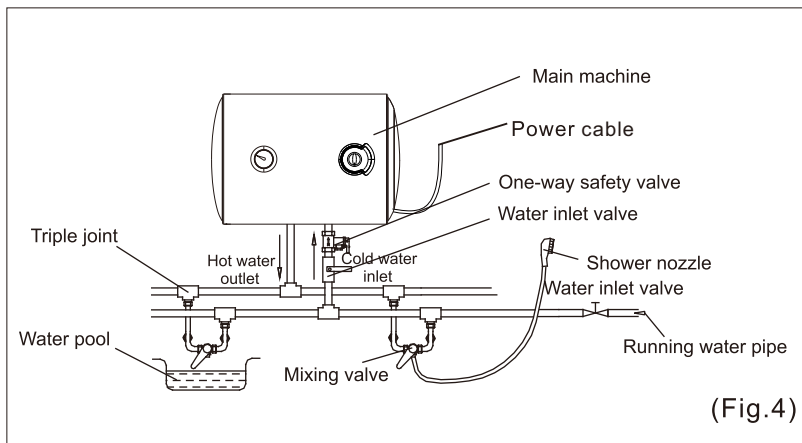

Methods of use

1. First, open any one of the outlet valves at the outlet of the water heater, then, open the inlet valve. The electric water heater begins to be filled with water. When there is water coming out of the outlet valve normally, it implies that the heater has been filled fully with water, and the outlet valve can be closed.

Note: During normal operation, the inlet valve shall be set in the status of “open”.

2. Insert the supply plug into the socket, the power indicator lights are on at this time.
3. This machine can automatically control the temperature. When the water temperature inside the machine has reached the set temperature (It is set to 75°C), it will be turned off automatically, and step into the status of thermal insulation; when the water temperature is decreased to a certain point, it will be turned on automatically to restore the heating, and the use of hot water will not be interrupted. When the heater is switched off automatically, the heating indicator will turn off.

Cautions

1. The supply socket must be earthed reliably. The rated current of the socket shall not be lower than 16A. The socket and plug shall be kept dry to prevent electric leakage. Inspect frequently whether the plugs contact well with the socket. Inspect method is as follows: insert the power supply plug into socket, after using for half an hour, shut down the unit and pull the plug out, and inspect the plug whether it scalds hand. If it scalds (over 50°C), please change another well-contacted socket to avoid the plug being damaged, fire or other personnel accidents result from bad-contacting.

2. For the places or the wall where the water may splash, the installation height of the socket shall not be lower than 1.8m.
3. The wall in which the electric water heater is installed shall be able to bear the load more than two times of the heater filled fully with water without distortion and cracks. otherwise, other strengthening measures shall be adopted.
4. The one-way safety valve attached with the machine must be installed at the cold water inlet of this machine (see Fig.5).

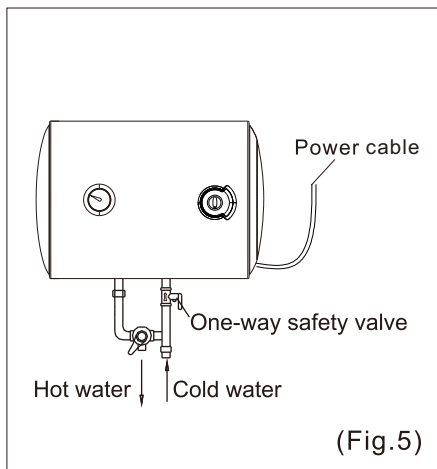

5. For the use of the first time (or the first use after maintenance or clean), the heater can not be switched on until it has been filled fully with water. When filling the water, at least one of the outlet valves at the outlet of the heater must be opened to exhaust the air. This valve can be closed after the heater has been filled fully with water.
6. During heating, there may be drops of water dripping from the pressure release hole of the one-way safety valve. This is a normal phenomenon. If there is a large amount of water leaked, please contact with the professional maintenance personnel for repair. This pressure release hole shall, under no circumstances, be blocked; otherwise, the heater may be damaged, even resulting in safety accidents.
7. The drainage pipe connected to the pressure release hole must be kept sloping downwards.
8. Since the water temperature inside the heater can reach up to 75°C, the hot water must not be exposed to human bodies when it is initially used. Adjust the water temperature to a proper point to avoid scald.
9. In order to drain away the water inside the inner container, it can be drained away from the exit port (Twist the thread screw of the exit port off), and it also can be drained away from the one-way safety valve (Twist the thread screw off the one-way safety valve, and lift the drain handle upwards).
10. If the flexible power supply cord is damaged, the special supply cord provided by the manufacturer must be selected, and replaced by the professional maintenance personnel.

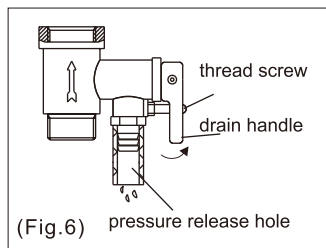

- If any parts and components of this electric water heater are damaged, please contact with the professional maintenance personnel for repair, and use the special spare parts and components provided by our company.

Maintenance

- Check the power supply plug and socket frequently to make sure that they have good, reliable contact and are well grounded without overheat phenomenon.
- If the heater will not be used for a long time, especially in the regions with low atmospheric temperature (lower than 0°C), in order to prevent the heater to be damaged due to freeze of the water in the inner container, the water inside the heater shall be drained away (refer to Item 9, Cautions of this manual for the method to drain away the water inside the inner container).
- In order to ensure that the water heater can operate efficiently for long term, it is recommended to clean periodically the inner container and the deposits on the electrical heating components of the electric water heater.
- Suggest to examine the anode protection materials every half a year or so. If all the materials have been consumed, please replace with the new materials.

Failures and treatment

| Failures | Reasons | Treatment |
|--|---|---|
| The heating indicator light is off. | Failures of the temperature controller. | Contact with the professional personnel for repair. |
| No water coming out of the hot water outlet. | <ol style="list-style-type: none"> The running water supply is cut off. The hydraulic pressure is too low. The inlet valve of running water is not open. | <ol style="list-style-type: none"> Wait for restoration of running water supply. Use the heater again when the hydraulic pressure is increased. Open the inlet valve of running water. |
| The water temperature is too high. | Failures of the temperature control system. | Contact with the professional personnel for repair. |
| Water leak | Seal problem of the joint of each pipe. | Seal up the joints. |

Wiring diagram

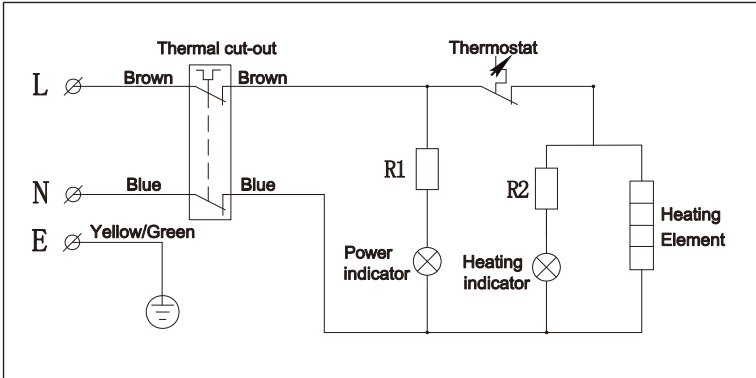

The product is subject to change without notice.
Please keep this manual properly.